

International Conference on Space Optics—ICSO 2012

Ajaccio, Corse

9–12 October 2012

Edited by Bruno Cugny, Errico Armandillo, and Nikos Karafolas



Hyperspectral imager for components identification in the atmosphere

Jean-Luc Dewandel

Didier Beghuin

Xavier Dubois

Philippe Antoine



Hyperspectral Imager for Components Identification in the Atmosphere

Jean-Luc Dewandel, Didier Beghuin, Xavier Dubois, Philippe Antoine
Lambda-X SA,
Nivelles, Belgium
jldewandel@lambda-x.com

Abstract— Several applications require the identification of chemical elements during re-entry of material in the atmosphere. The materials can be from human origin or meteorites. The Automated Transfer Vehicle (ATV) re-entry has been filmed with conventional camera from airborne manual operation. In order to permit the identification of the separate elements from their glow, spectral analysis needs to be added to the video data. In a LET-SME contract with ESA, Lambda-X has built a Fourier Transform Imaging Spectrometer to permit, in a future work, to bring the technology to the readiness level required for the application. In this paper, the principles of the Fourier Transform Imaging spectroscopy are recalled, the different interferometers suitable for supporting the technique are reviewed and the selection process is explained. The final selection of the interferometer corresponds to a birefringent prism based common path shear interferometer. The design of the breadboard and its performances are presented in terms of spatial resolution, aperture, and spectral resolution. A discussion is open regarding perspective of the technique for other remote sensing applications compared to more usual push broom configurations. (*Abstract*)

Index Terms— Hyperspectral, Fourier transform, spectrometer (*key words*)

I. INTRODUCTION

Meteorites furtively enlightening a straight line of the black night sky keep on bearing mysteries. For space objects of human origin re-entering the atmosphere on the other hand, mastering the process should be more than wishes. In this context, the European Space Agency (ESA) set up a small project to start development of analytical instrument capable of providing information regarding local composition of elements in decomposition in the atmosphere.

The purpose of ESA was to setup the bases of an imager capable to track re-entering glowing elements from airborne platform. The imager should further be capable of providing local spectral information. One of the targeted objects to be monitored in its re-entry is the Automated Transfer Vehicle (ATV). ATV re-entry shows an explosive split of the vehicle several seconds after the first glows are detected. ESA is interested in the identification of the constituting elements that are glowing due to the local high temperature.



Fig. 1 ATV reentry picture acquired with RGB camera

The applications is quite demanding in spectral and resolution performances, but is also quite challenging for environmental aspects, not that the temperature or shocks are extreme, but the acquisition must occur from airborne platform so the system must cope with vibration, sight stabilization and object tracking.

From the many possible technologies for acquiring hyperspectral imaging data, the choice was made to work with Fourier transform based systems. Those techniques present advantages in terms of signal to noise ratio and are relatively easy to setup. The principle is widely used in the infrared domain and referred as FTIR spectrometers, typically in Michelson type interferometers. For the visible wavelengths and for imaging purposes, several different types of interferometers can be setup to generate the interferograms. Some of them present common path for the two arms and thereby ensure high stability in the interferences.

The spectral range to be covered ranges from the UV to the NIR (350nm to 1000nm typically). The acquisition shall occur in a short period of time and permit fast imaging of the phenomenon.

This paper recalls the principles of the Fourier spectrometry, and presents a short review of the several different types of interferometers suitable for visible Fourier transform imaging spectrometers. A section is dedicated to the description of the realized breadboard. The experimental performances of the system are described. The paper then concludes with a discussion regarding the potential applications of this technique.

II. TECHNOLOGICAL SOLUTION SURVEY

The fundamental principle of the imaging Fourier Transform Spectrometry (FTS) technique consists in splitting in two arms the beam issued from a single object point and to recombine them in the stigmatic image of this object point on a camera. The split and recombination shall occur for all stigmatic image point of the object. Means in the interferometer must be included to modify the optical path length difference (OPD) between the two arms and for each successive image acquisition. For a dedicated object point, several acquisitions corresponding to several OPD in the interferometers are thus recorded. If the OPD step is constant between successive acquisitions, the amplitude of the Fourier transform of the temporal records corresponding to an object point then provides the emission power spectrum of this point.

Imaging Fourier spectrometer can ensure better signal to noise ratio compared to other type of spectrometers of comparable optical characteristics, because of the etendue advantage (no slit limiting the photon flux to the one passing the slit) and to the multiplex advantage (every pixel receives signal from all wavelengths). Although this latter advantage must be mitigated for shot noise limited systems and can even become disadvantageous when the purpose of the measurement is to characterize absorption lines (compared to the most favorable case of characterization of emission lines).

Two different acquisition principles can be used for recording the object point interferogram; either the scene is fixed in the image plane (framing mode according to Sellar [3]), either it is scanned laterally (windowing [3]). In the first case the OPD between the two arms must then be step modified between two successive image acquisitions. This first framing mode inevitably requires a mechanical movement in the interferometer to scan the OPD. In the second option, the object is scanned along the image plane, and to each successive lateral position corresponds a different OPD. This second option can be practically realized from a fixed shear interferometer [1] [4].

For the purpose of keeping the re-entering object constantly in the field of view, it was decided to opt for the framing mode acquisition principle. An object tracking system including the use of a rotation table has been breadboarded but the results are not reported here.

In order to produce a robust system, a common path type interferometer was selected. One of the simplest optical systems was described by Padgett and Harvey [5], [6] and a similar configuration was selected for the breadboard. In this configuration shown in Fig. 2, two paired Wollaston prisms are aligned one after each other such that the two polarization beams output parallel. Polarizers are used as projectors to force interference between the two orthogonal polarizations. By displacing laterally one of the two Wollaston with respect to the other one, the OPD can be modified for all field points.

The data processing occurs independently for every pixel of the camera. The power spectrum of the field point emission is recovered by Fourier transform of the temporal signal obtained for every pixel. Apodisation of the interferogram as well as data resampling must be applied to compensate for imperfect

linear motion of the scan stage and by such to reduce artefacts in the recovered spectra.

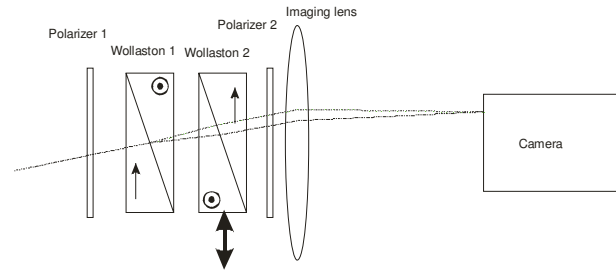

Fig. 2 Schema of the interferometer

III. BREADBOARD TEST SETUP

A materialization of the interferometer has been realized from either off the shelf or custom made components. The imaging lens is 60mm focal length from coastal optics and is corrected from 315nm to 1100nm. The Wollaston prisms are made of quartz with 0.5 deg split angle and 30mm clear aperture. The lateral displacement of one Wollaston prism is performed with PI motorized scan stage M122. The camera is 1.4MPix from Baumer (TFX 13). Polarizers are wire grid based. The CAD model is shown in Fig. 3. The total length of the spectral imager is less than 230mm.

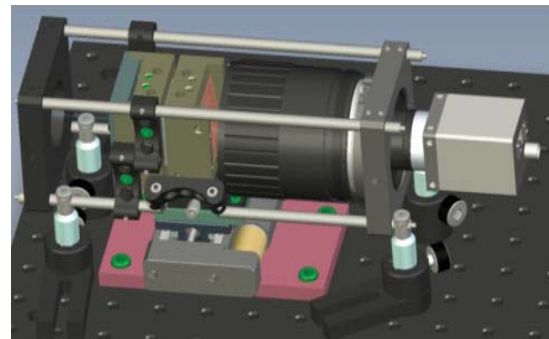

Fig. 3 CAD model of the setup

The main features of the system are summarized in Table 1.

TABLE I. IMAGING SPECTROMETER GENERAL FEATURES

Imaging spectrometer performances	
Scan head dimensions [mm]	100 H X 100 W x 80D (without camera and objective).
Spectral range [nm]	350 to 1000
Maximum Spectral resolution	100 cm-1 (3nm@550nm)
Imaging sensor resolution	1392x1040
Spectrum measurement rate (resolution dependent)	100Hz ROI (70x70 pixels): 12 Sec for 100cm-1 6 sec for 200 cm-1
FOV	Full FOV: 6.1° x 4.6°

The distance between the two Wollaston prisms is responsible of shearing as show in Fig. 2. A parallel ray pencil is split by the first Wollaston prism and the two split pencils are set parallel by the second Wollaston prism. The larger the

distance between the Wollaston prisms the larger is the separation between the ray pencils. This shear is responsible of residual fringes in the image; the OPD is thus field dependent and the acquisition scheme and data processing take this into account.

IV. EXPERIMENTAL RESULTS

The next two graphs (Fig. 4 and Fig. 5) show the spectral performances of the instrument for emission from spectral reference Hg Ar gas discharge source (HG-1, Ocean Optics). All significant peaks of the source are detected. As the Fourier spectrometer is a system with constant resolution in term of wavenumber, the resolution in terms of wavelengths increases as the square of the source wavelength, so in the near infrared, some of the peaks are not resolved (Fig. 5).

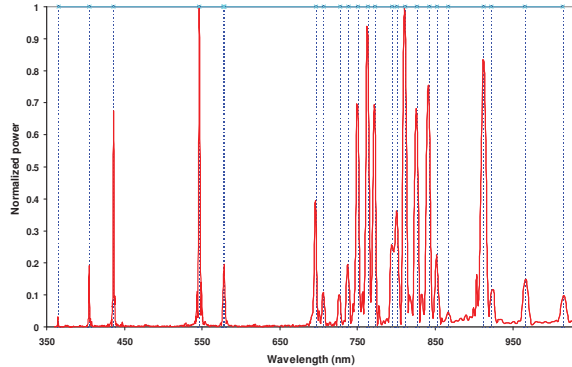

Fig. 4. Source spectrum recovery for 350nm to 1000nm spectral range

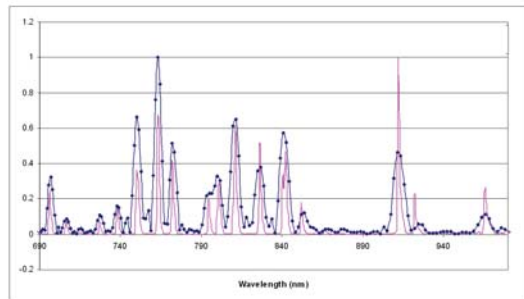

Fig. 5. Source spectrum (a.u.) recovery for 690nm to 1000nm spectral range, experimental data (dotted curve), reference spectrum (continuous curve)

The imaging features are not affected by the presence of the interferometer, so the imaging quality is the same as the one of the imaging optics. Fig. 6 shows the spectral imaging of several fruits. A fiber distal end of fiber coupled HeNe laser is imaged with the field for the purpose of calibration.

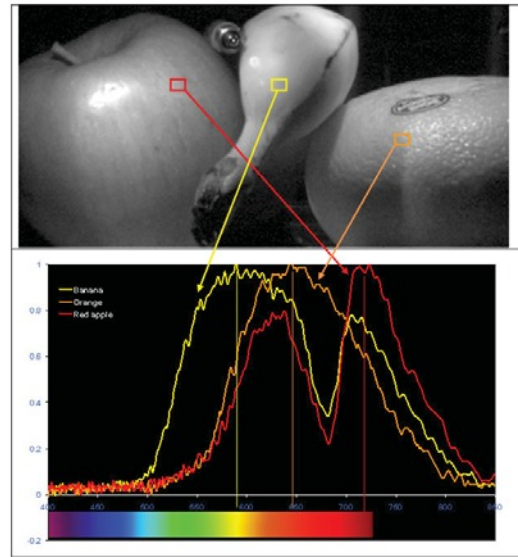

Fig. 6. Fruit imaging and local emission spectrum recovery (a.u.)

V. DISCUSSIONS AND CONCLUSIONS

The realization of the breadboard proved that compact and robust interferometer can be built for framing mode spectral imaging. The spectral resolution that can be obtained is typically dependent on the maximum OPD. The maximum OPD is determined practically by the number of images that can be acquired and more fundamentally by the size of the Wollaston prisms. Calcite Wollaston can prove to be more adapted to this configuration but are more difficult to produce in large dimensions and are typically more expensive. The spectral range is entirely determined by the spectral response of the detector camera

The Fourier based spectral imager based on birefringent prisms is well adapted for applications demanding high signal to noise ratio where engineering and financial budgets are limited. By appropriate prism designs, the same type of interferometer can be adapted to the windowing mode imaging technique, well adapted to airborne or spacecraft based remote sensing. In this case, the prisms ensure a large shear, which in turn is responsible of the field dependent OPD. The shear shall be produced in the along track to permit any ground point to pass successively to all stepped OPD.

ACKNOWLEDGMENT

This program has been funded by the European Space Agency (ESTEC CONTRACT No. 22860/09/NL/VS). We thank Robert Lindner for his expertise and collaboration all along the program

- [1] A. Barducci, D. Guzzi, C. Lastrì, P. Marcoianni, V. Nardino, and I. Pippi, "Theoretical Aspects of Fourier Transform Spectrometry and Common Path Triangular Interferometers", *Optics Express* 11, Vol.18, pp.11622, 2010.
- [2] <http://www.youtube.com/watch?v=e2OIAk112vs>

- [3] R.G. Sellar and G.D. Boreman, 'Classification of imaging spectrometers for remote sensing applications', *Optical Engineering*, 44(1), 1-3, 2005.
- [4] Y. Ferrec, 'Spectro-imagerie aéroportée par transformation de Fourier avec un interféromètre statique à décalage lateral: réalisation et mise en oeuvre', Ph.D. thesis, Laboratoire Charles Fabry de l'Institut d'Optique, Université Paris-Sud XI, 2008
- [5] M.J. Padgett and A.R. Harvey, "A static Fourier-transform spectrometer based on Wollaston prisms," *Rev. Sci. Instrum.* 66, 2807-2811 (1995)
- [6] A.R. Harvey and D.W. Fletcher-Holmes, 'Birefringent Fourier-transform imaging spectrometer', *Optics Express*, vol. 12(22), pp. 5368, 2004